

# Fluid control valve(2/2way)

## 2KW Series (Internally piloted and normally opened )

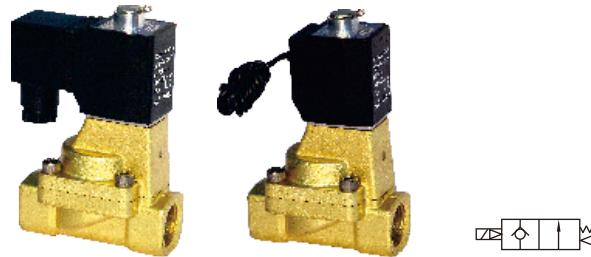

### Ordering code

Ordering code of valves

**2KW 150 15 A □ T**

① ② ③ ④ ⑤ ⑥

① Model	② Orifice size	③ Port size	④ Voltage	⑤ Electrical entry	⑥ Thread type
2KW: 2/2 way internally piloted and normally opened	150: Φ15mm	15: 1/2"	A: AC220V B: DC24V C: AC110V E: AC24V F: DC12V	Blank: Terminal I: Grommet	T: NPT
	200: Φ20mm	20: 3/4"			
	250: Φ25mm	25: 1"			

### Ordering code of accessories

Ordering code of accessories is the same as 2S series valve's, Please refer to P150 for details of ordering code.

### Specification

Model\Item	Port size [Note1]	Orifice size (Φ mm)	Cv	Valid area or section (mm <sup>2</sup> )	Weight [Note2](g)	Operating pressure differentia		Proof pressure	
						MPa	psi	MPa	psi
2KW150-15	1/2"	15.0	5.50	100.0	730	Max: 0.7 Min: 0.05	Max: 100 Min: 10	1.5	220
2KW200-20	3/4"	20.0	9.50	170.0	960				
2KW250-25	1"	25.0	12.50	220.0	1210				

[Note1] NPT thread is available.

[Note2]The weight in the table is the terminal valve's weight, grommet valve's weight is 10g less than terminal's.

### Specification of coil

Valve type	Coil type	Power type	Frequency (Hz)	Voltage range	Electrical entry	Power Consumption (VA/W)	Insulation	Temp. rise(°C)
2KW150 2KW200 2KW250	CDA116 CLA116	AC	50	± 15%	Terminal (CDA) Grommet (CLA)	15.0VA	Class B	50
			60			11.0VA		40
	DC	-	± 10%	6.5W		30		

# Fluid control valve(2/2way)

## 2KW Series (Internally piloted and normally opened )

### Product feature

1. Indirect acting (Internal pilot) and normally opened type 2/2 way solenoid valve. Its can change direction quickly and has large flow.
2. It is compact, small and light weight. It is easy to install and dismantle;
3. The valve body is made of brass . The coil has a Heat resistance classification of Class B. The standard seal material is FPM-F. Please contact us if other material are required.
4. The protection class of the coil is IP65 and there is a choice for grommet or terminal electrical entry .

### Flow chart

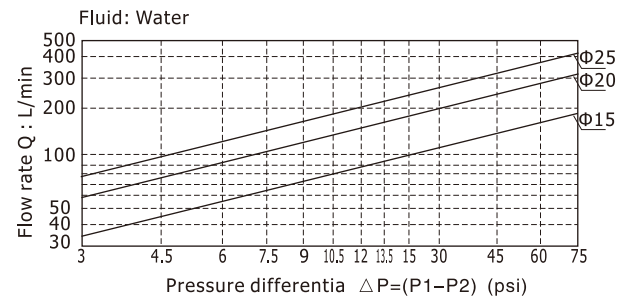
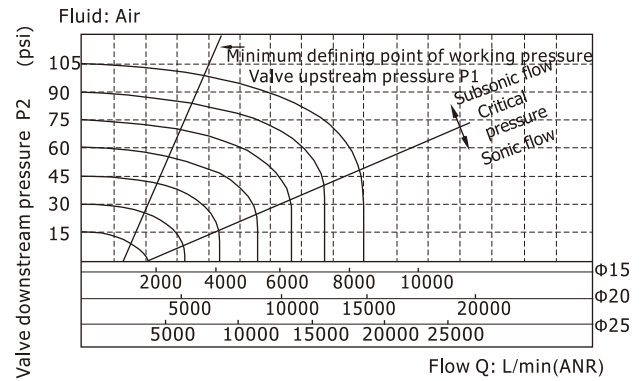

### Valve's specification

Acting		Internally piloted				
Initial state		Normally opened				
Adaptable fluid		Air, Water, Oil				
Viscosity limit		Under 20CST				
Ambient and fluid temperature ( °C )		Water	Air	Oil	Ambient	
	Max.	80	90	80	70	
	Min.	1	-20 [Note1]	-10 [Note2]	-20	

[Note1] Dew point: -20(°C) or less;

[Note2] 50CST or less.

### Dimensions

#### 2KW150~250 (Terminal)

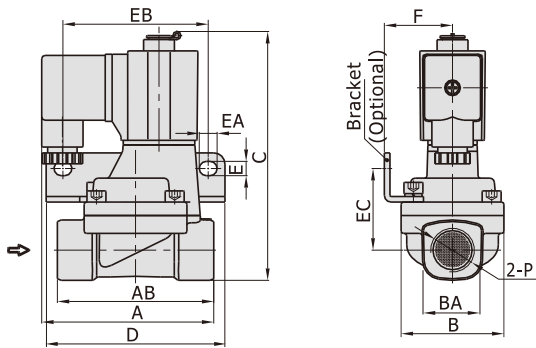

#### 2KW150~250(Grommet)

[Unit: mm]

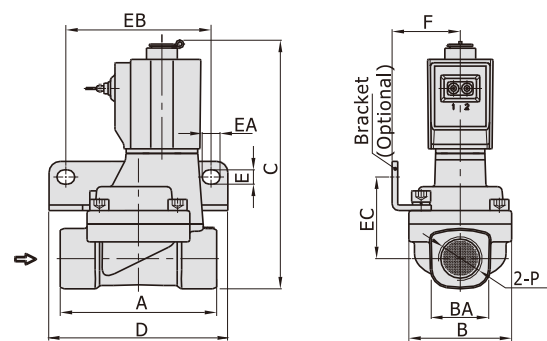

Model\Item	A	AB	B	BA	C	D	E	EA	EB	EC	F	P
2KW150-15	77	70	46	27.5	112.5	80	6.4	8	65	36.5	30.5	1/2"
2KW200-20	78.5	82	53	33.5	121	90	6.4	8	75	40	34	3/4"
2KW250-25	81	92	59	40.5	129.5	95	6.4	8	80	44.5	36	1"

Model\Item	A	B	BA	C	D	E	EA	EB	EC	F	P
2KW150-15	70	46	27.5	112.5	80	6.4	8	65	36.5	30.5	1/2"
2KW200-20	82	53	33.5	121	90	6.4	8	75	40	34	3/4"
2KW250-25	92	59	40.5	129.5	95	6.4	8	80	44.5	36	1"