

Fluid control valve(2/2way)

2S Series (Direct-acting and normally closed)

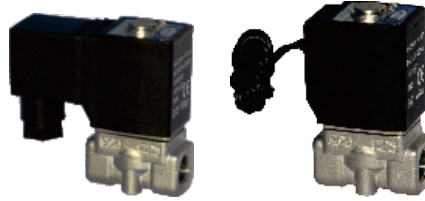

Ordering code

Ordering code of valves

2S L 030 08 A □ T

① ② ③ ④ ⑤ ⑥ ⑦

① Model	② Pressure condition	③ Size series	④ Port size	⑤ Voltage	⑥ Electrical entry	⑦ Thread type
2S: 2/2 way direct-acting and normally closed	X: Extra high pressure H: High pressure Blank: Standard L: Large volume T: Extra large volume	030: 030 Series	06: 1/8" 08: 1/4"	A: AC220V B: DC24V C: AC110V E: AC24V F: DC12V	Blank: Terminal I: Grommet	T: NPT
		050: 050 Series	10: 3/8" 15: 1/2"			

Ordering code of accessories

F-2S030 LB

① ② ③

① Accessories code	② Valve type	③ Accessories type
F: Mounting accessories	2S030: 030 Series valve 2S050: 050 Series valve	LB: LB Type

Specification

Model\Item	Port size [Note1]	Orifice size (Φ mm)	Cv	Valid area or section (mm ²)	Weight [Note2](g)	Max.operating pressure differentia		Proof pressure	
						MPa	psi	MPa	psi
2SX030	-06 1/8"	1.5	0.10	1.8	300	3.0	450	5.0	750
	-08 1/4"				295				
2SH030	-06 1/8"	2.0	0.18	3.0	300	2.0	300		
	-08 1/4"				290				
2S030	-06 1/8"	3.0	0.33	6.0	300	1.0	150		
	-08 1/4"				290				
2SL030	-06 1/8"	4.0	0.55	10.0	300	0.5	75		
	-08 1/4"				290				
2ST030	-06 1/8"	6.0	1.10	12.0	300	0.1	15		
	-08 1/4"				290				
2SX050	-10 3/8"	3.0	0.34	6.1	600	3.0	450		
	-15 1/2"				590				
2SH050	-10 3/8"	4.0	0.55	10.0	600	2.0	300		
	-15 1/2"				590				
2S050	-10 3/8"	5.0	0.83	15.0	600	1.0	150		
	-15 1/2"				590				
2SL050	-10 3/8"	7.0	1.40	25.0	600	0.5	75		
	-15 1/2"				590				
2ST050	-10 3/8"	10.0	2.20	40.0	600	0.1	15		
	-15 1/2"				590				

[Note1] NPT thread is available.

[Note2] The weight in the table is the terminal valve's weight, 2S030 series grommet valve's weight is 10g less than terminal's. 2S050series grommet valve's weight is 20g less than terminal's.

Fluid control valve(2/2way)

2S Series (Direct-acting and normally closed)

Product feature

1. Direct acting and normally closed type 2/2 way solenoid valve.
Its high sensibility allows it to change direction quickly;
2. It has wide pressure range, including extra high pressure (X), high pressure (H), standard, large volume(L) and extra large volume (T) to choose from;
3. It is compact, small size and light weight.
It is easy to install and dismantle.
4. The valve body is made of SUS304 .
Its coil has a Heat resistance classification of Class B. The standard seal material is FPM-F. Please contact us if other material are required.
5. The protection class of the coil is IP65 and there is a choice for grommet or terminal electrical entry .

Flow chart

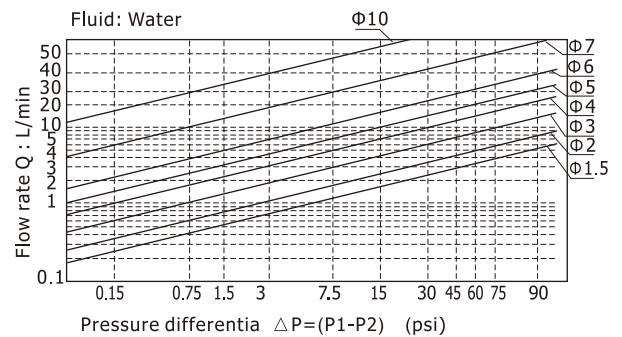
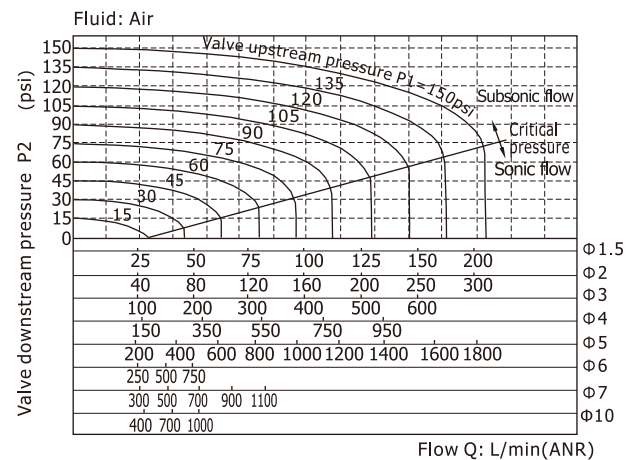

Valve's specification

Acting	Direct acting				
Initial state	Normally closed				
Adaptable fluid	Air, Water, Oil				
Viscosity limit	Under 20CST				
Ambient and fluid temperature (°C)		Water	Air	Oil	Ambient
	Max.	80	90	80	70
	Min.	1	-20 [Note1]	-10 [Note2]	-20

[Note1] Dew point: -20(°C) or less;

[Note2] 50CST or less.

Specification of coil

Valve type	Coil type	Power type	Frequency (Hz)	Voltage range	Power Consumption (VA/W)	Electrical entry	Insulation	Temp.rise (°C)
2S□030	CDA116 CLA116	AC	50	± 15%	10.0VA	Terminal (CDA) Grommet (CLA)	Class B	35
			60		8.0VA			30
2S□050	CDA170 CLA170	DC	-	± 10%	6.5W			30
			AC		50			± 15%
		60	22.0VA	55				
		DC	-	± 10%	10.5W			40

Fluid control valve(2/2way)

2S Series (Direct-acting and normally closed)

Dimensions

2S□030 (Terminal)

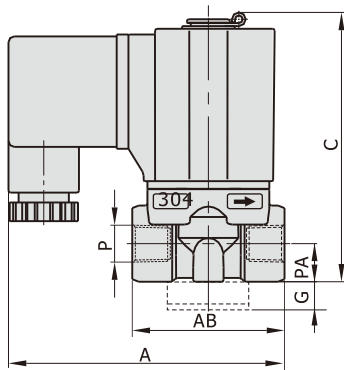
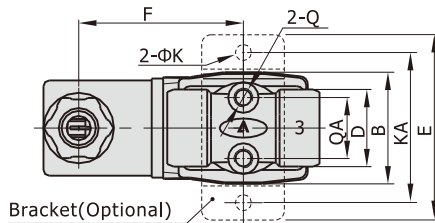

2S□030(Grommet)

[Unit: mm]

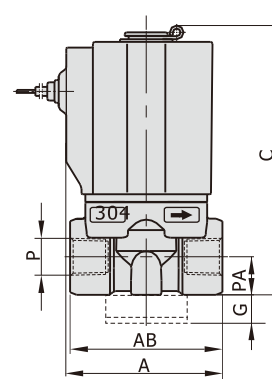
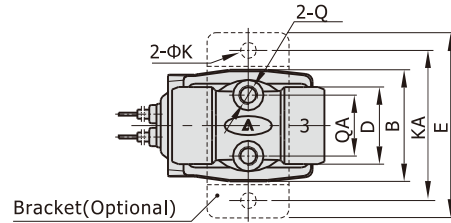

2S□050 (Terminal)

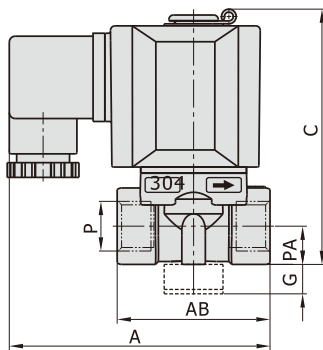
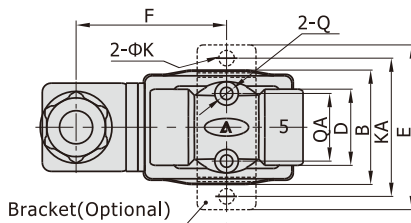

2S□050(Grommet)

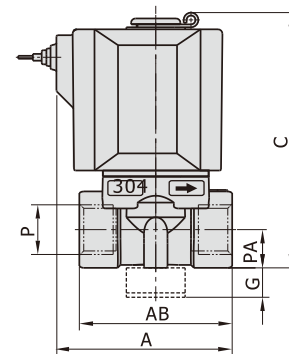
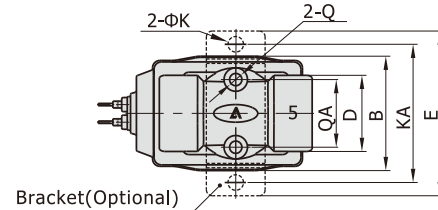

Model\Item	A	AB	B	C	D	E	F	G	K	KA	P	PA	Q	QA
2S□030-06	72.5	40	29.5	71	20	49	43.5	10	5.3	40	1/8"	10	M5	16
2S□030-08	72.5	40	29.5	71	20	49	43.5	10	5.3	40	1/4"	10	M5	16
2S□050-10	89.5	52	39	87	26	56	51	10	5.3	48	3/8"	13	M5	23
2S□050-15	89.5	52	39	87	26	56	51	10	5.3	48	1/2"	13	M5	23

Model\Item	A	AB	B	C	D	E	G	K	KA	P	PA	Q	QA
2S□030-06	41	40	29.5	71	20	49	10	5.3	40	1/8"	10	M5	16
2S□030-08	41	40	29.5	71	20	49	10	5.3	40	1/4"	10	M5	16
2S□050-10	60	52	39	87	26	56	10	5.3	48	3/8"	13	M5	23
2S□050-15	60	52	39	87	26	56	10	5.3	48	1/2"	13	M5	23