

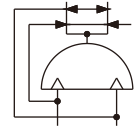

Compact air gripper—HFD Series

Bore size: $\Phi 8$, $\Phi 12$, $\Phi 16$, $\Phi 20$, $\Phi 25$

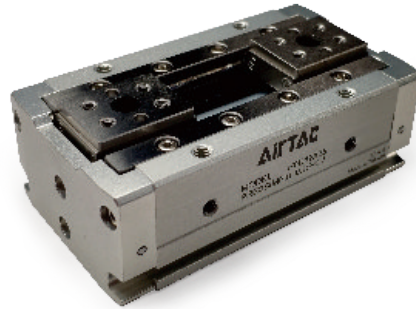

Ordering code

HFD 16 X 15

① ② ③

① **Model**
HFD: Compact air finger(Double acting)

② **Bore size**
8 12 16 20 25

③ Stroke	
Bore size	Stroke
8	8 15 30
12	10 25 50
16	15 30 60
20	20 40 80
25	40 80

Specification

Bore size (mm)		8	12	16	20	25
Acting type		Double acting				
Fluid		Air(to be filtered by 40 μ m filter element)				
Operating pressure		22~100psi(0.15~0.7MPa)				
Proof pressure		175psi(1.2MPa)				
Temperature		-20~70 $^{\circ}$ C				
Lubrication		Not required				
Repeatability mm		± 0.05				
Max. frequency	Longer stroke	60(c.p.m)				
	Middle and short stroke	120(c.p.m)				
Sensor switches		CMSH, DMSH(S)				
Port size		M3 \times 0.5	M5 \times 0.8			

Gripping force and stroke

Bore size	8			12			16			20			25	
Stroke (mm)	8	15	30	10	25	50	15	30	60	20	40	80	40	80
Gripping force per finger Effective value(N)	19			48			90			141			210	
Weight (g)	88.8	105.7	153.4	226.7	303.7	441.9	505.3	642.3	946.7	1019.6	1319.1	1983.3	1693.7	2558.9

[Note] The gripping force in the above table is in the working pressure of 75psi, and with a gripping point of L=20mm.



Compact air gripper



HFD Series

Bore size: $\Phi 8$, $\Phi 12$, $\Phi 16$, $\Phi 20$, $\Phi 25$

Dimensions

[Unit: mm]

HFD8X8

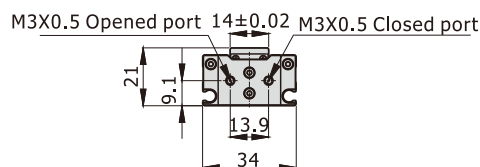
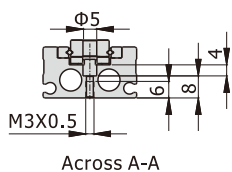
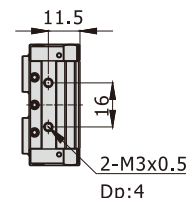
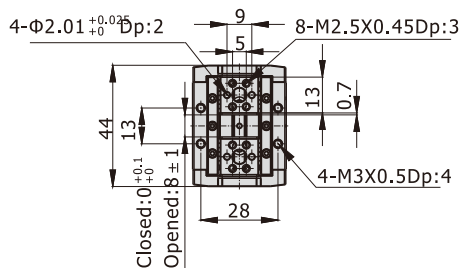
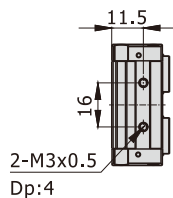
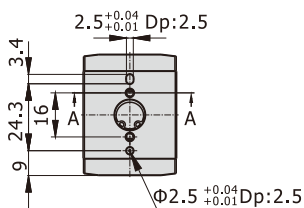

HFD8X15

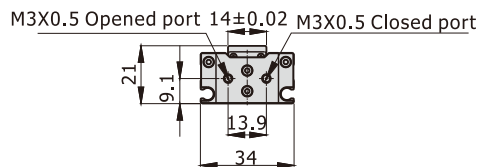
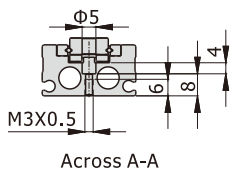
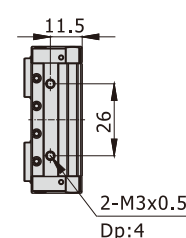
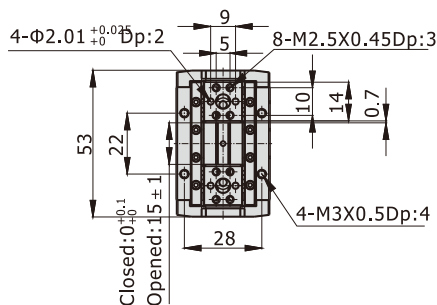
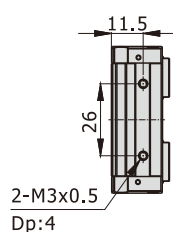
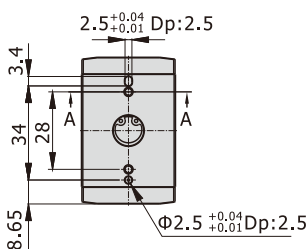

HFD8X30

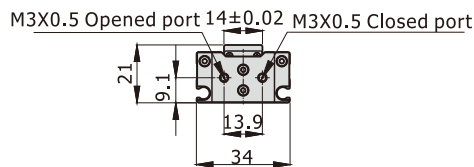
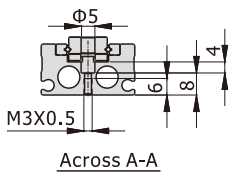
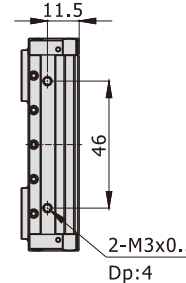
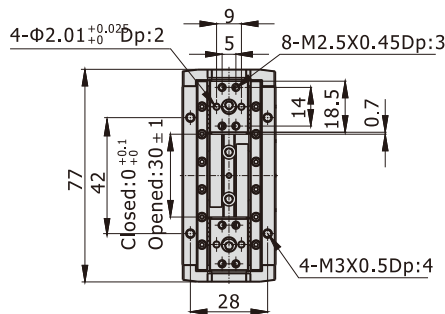
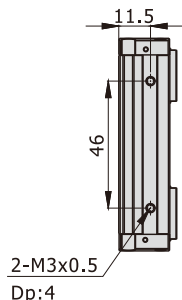
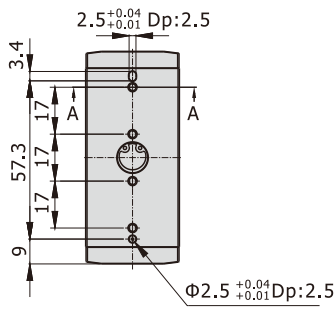

Compact air gripper

AIRTAC

HFD Series

Bore size: $\Phi 8$, $\Phi 12$, $\Phi 16$, $\Phi 20$, $\Phi 25$

HFD12X10

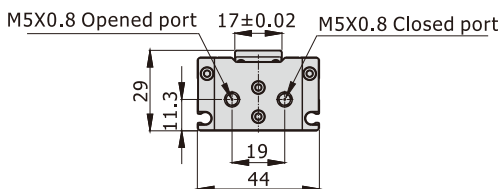
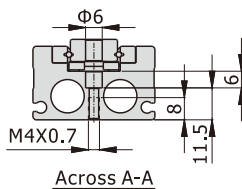
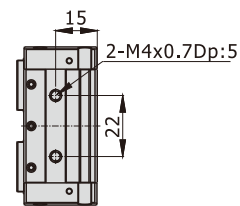
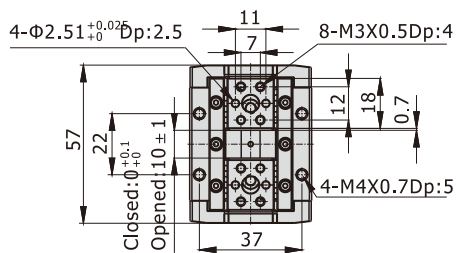
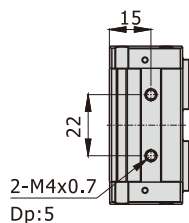
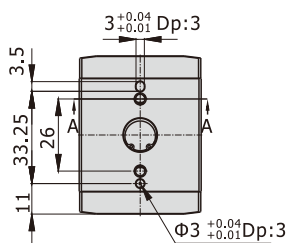

HFD12X25

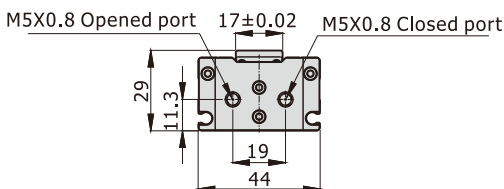
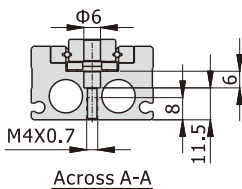
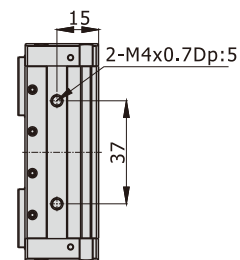
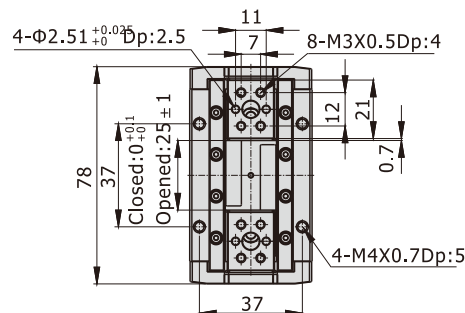
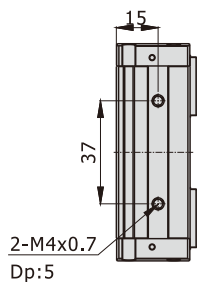
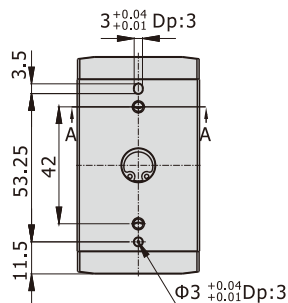

HFD12X50

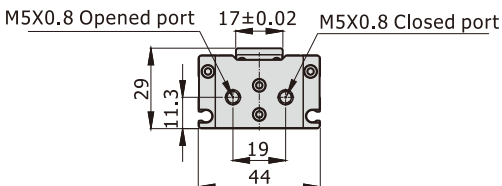
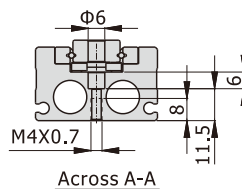
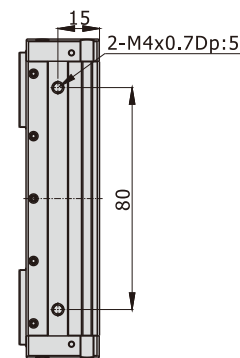
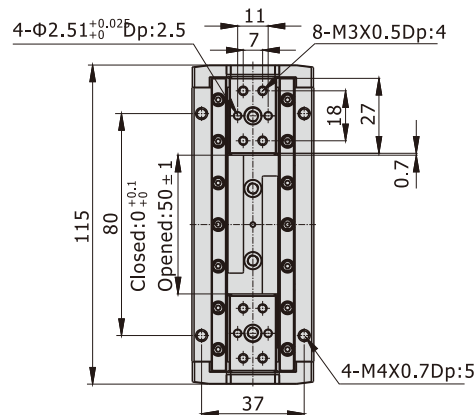
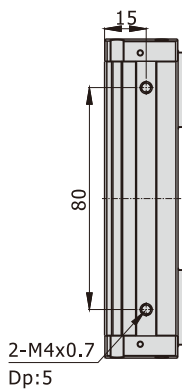
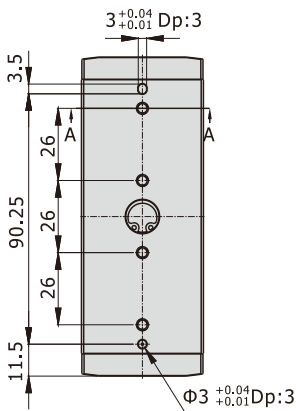

Compact air gripper

HFD Series

AIRTAC

Bore size: $\Phi 8$, $\Phi 12$, $\Phi 16$, $\Phi 20$, $\Phi 25$

HFD16X15

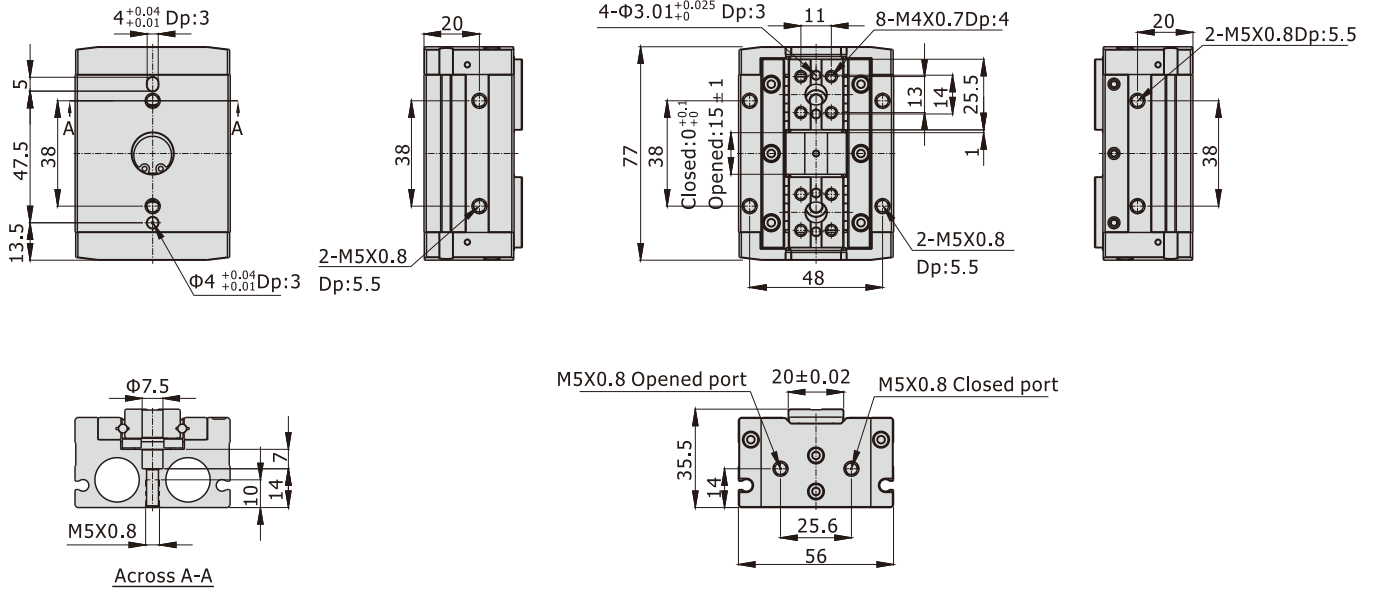

HFD16X30

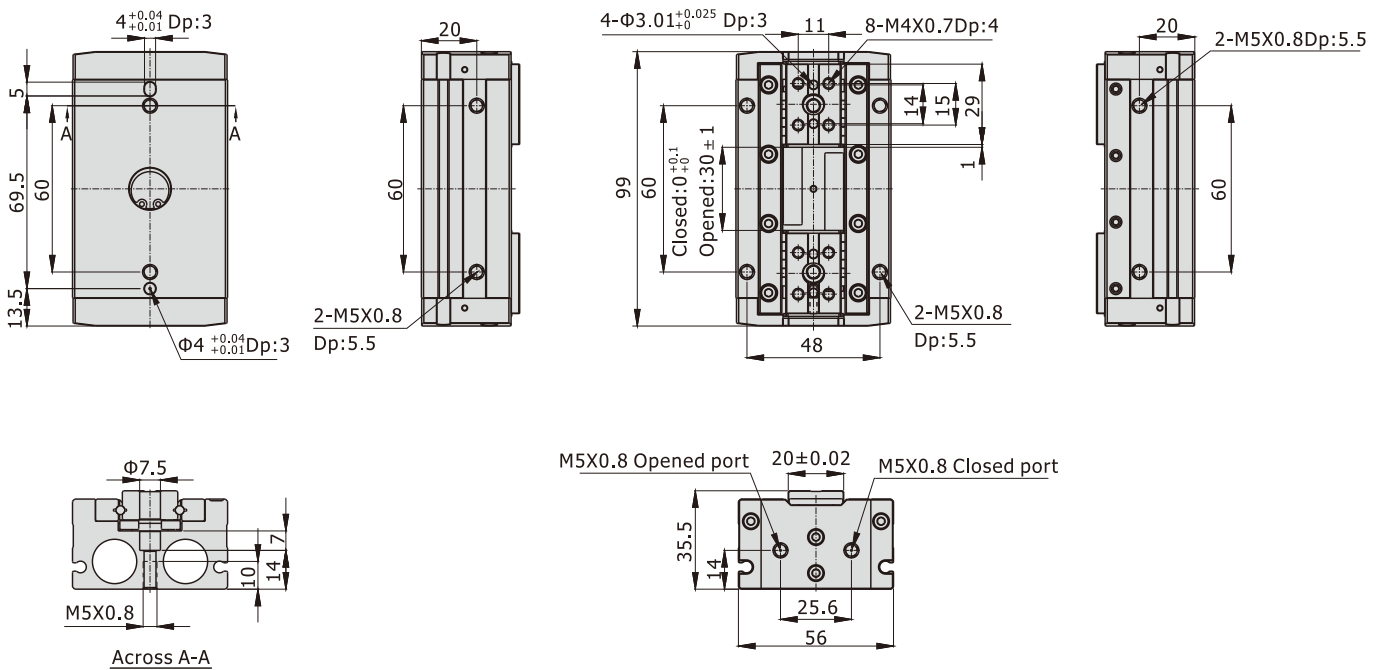

Compact air gripper

HFD Series

AIRTAC

Bore size: $\Phi 8$, $\Phi 12$, $\Phi 16$, $\Phi 20$, $\Phi 25$

HFD16X60

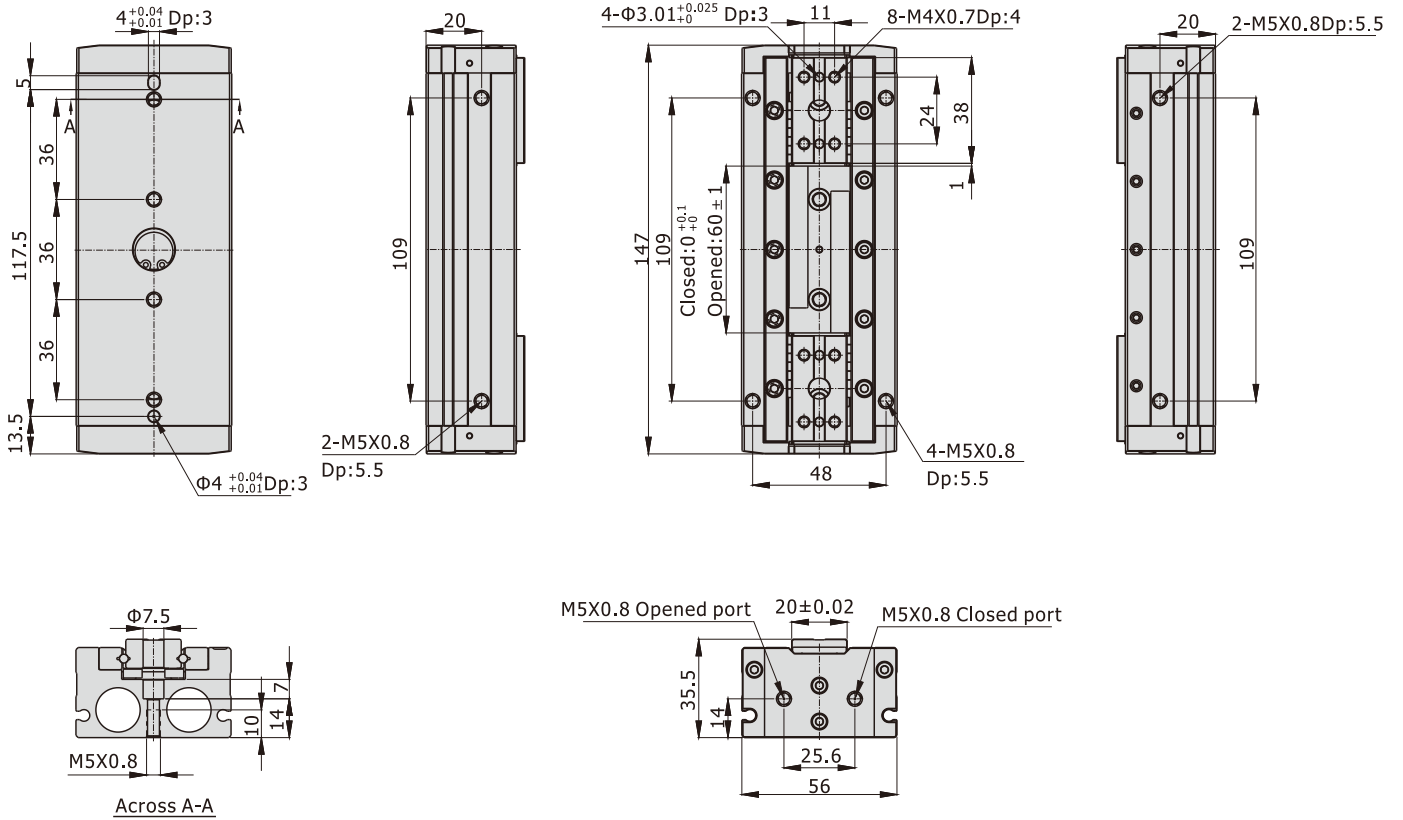

HFD20X20

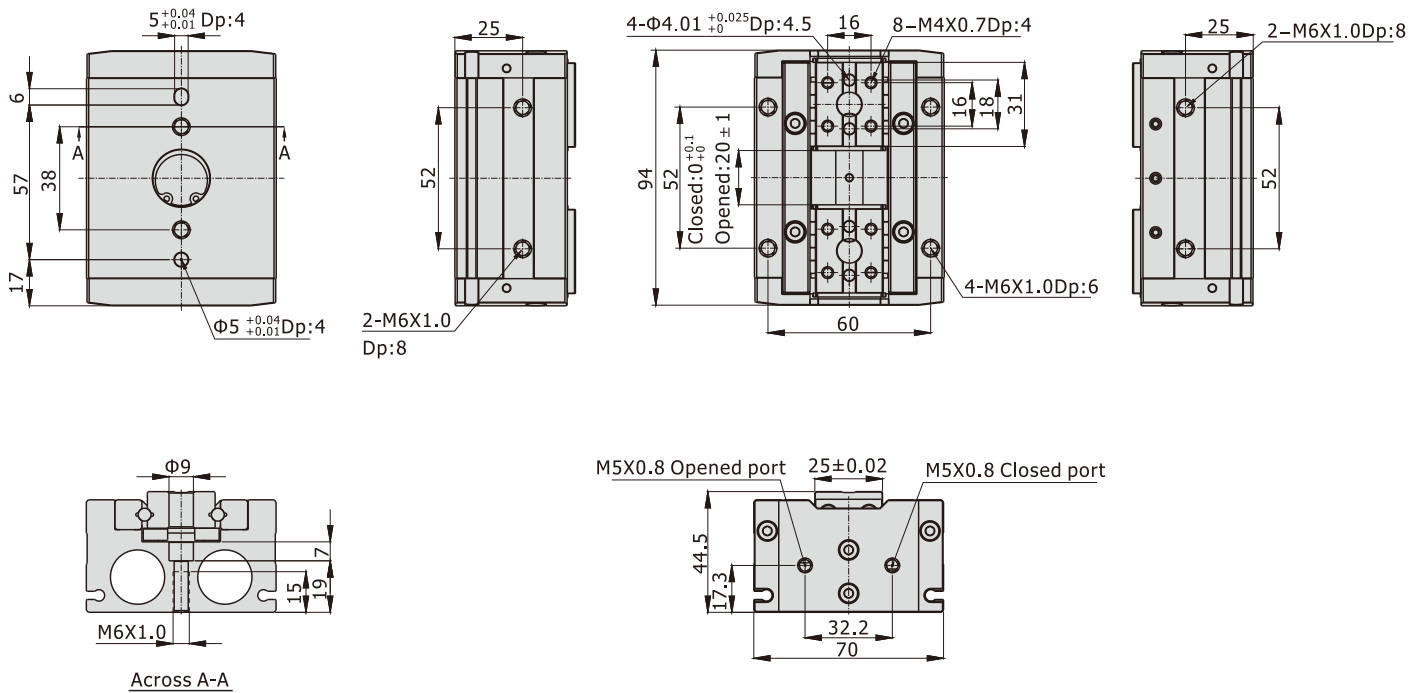

Compact air gripper

AIRTAC

HFD Series

Bore size: $\Phi 8$, $\Phi 12$, $\Phi 16$, $\Phi 20$, $\Phi 25$

HFD20X40

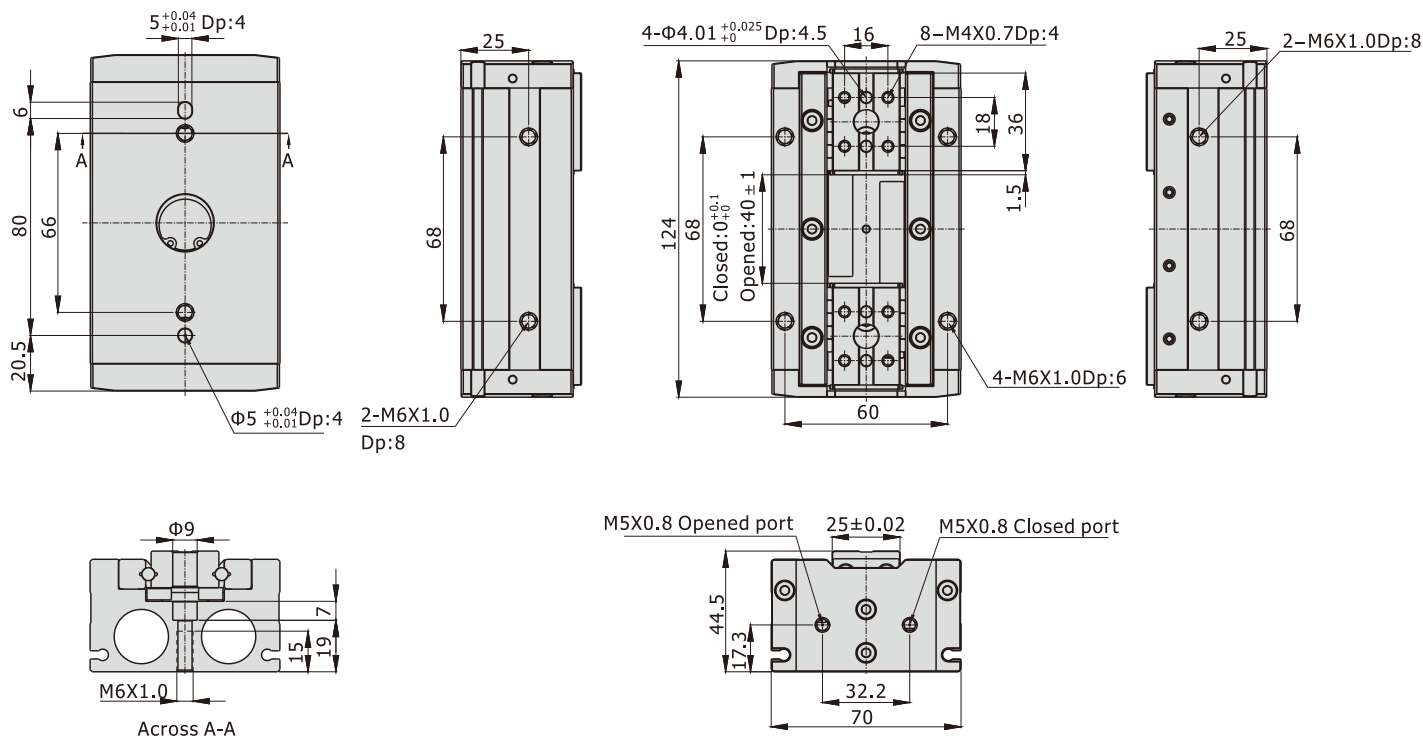

HFD20X80

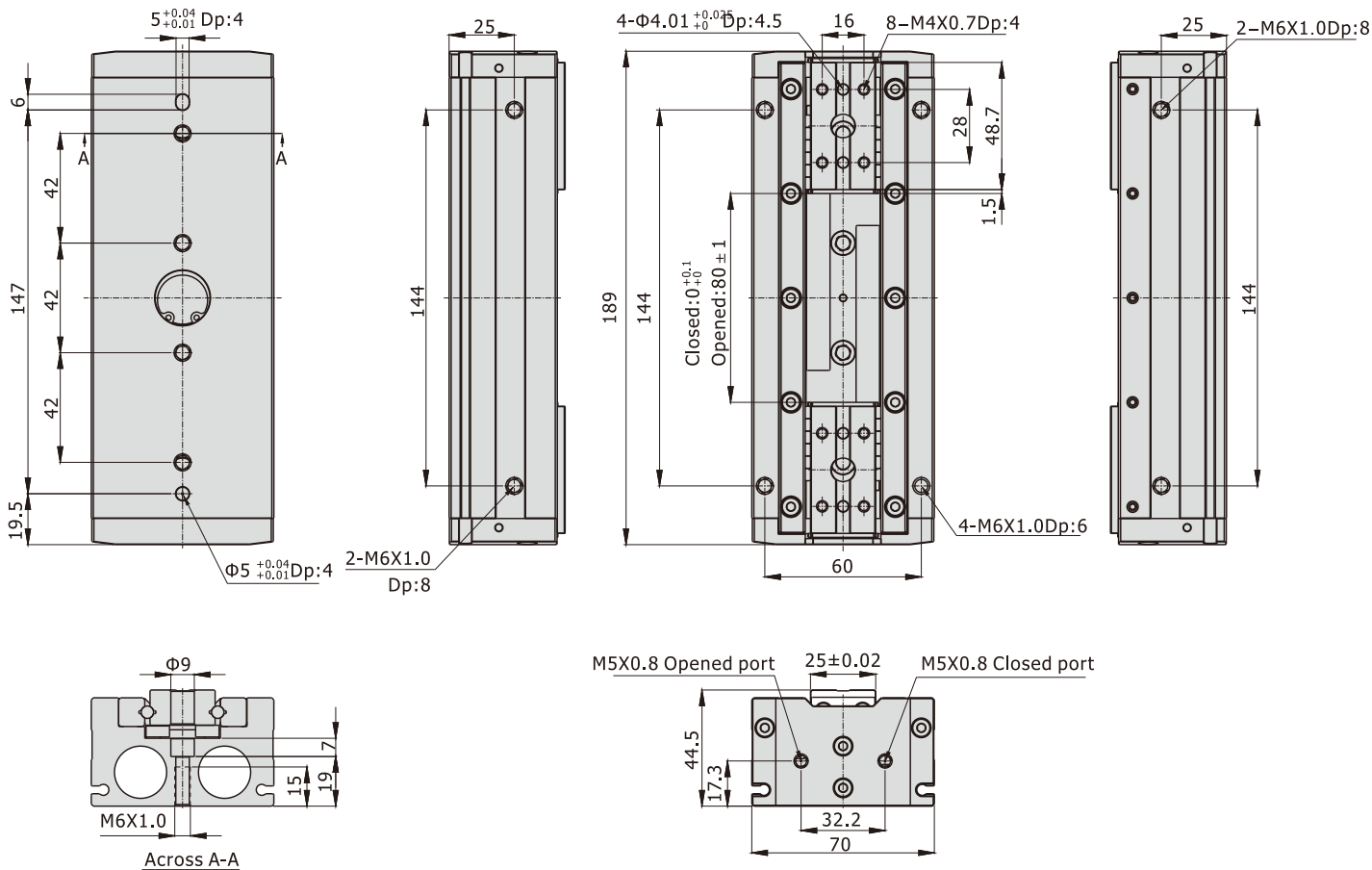

Compact air gripper

AIRTAC

HFD Series

Bore size: $\Phi 8$, $\Phi 12$, $\Phi 16$, $\Phi 20$, $\Phi 25$

HFD25X40

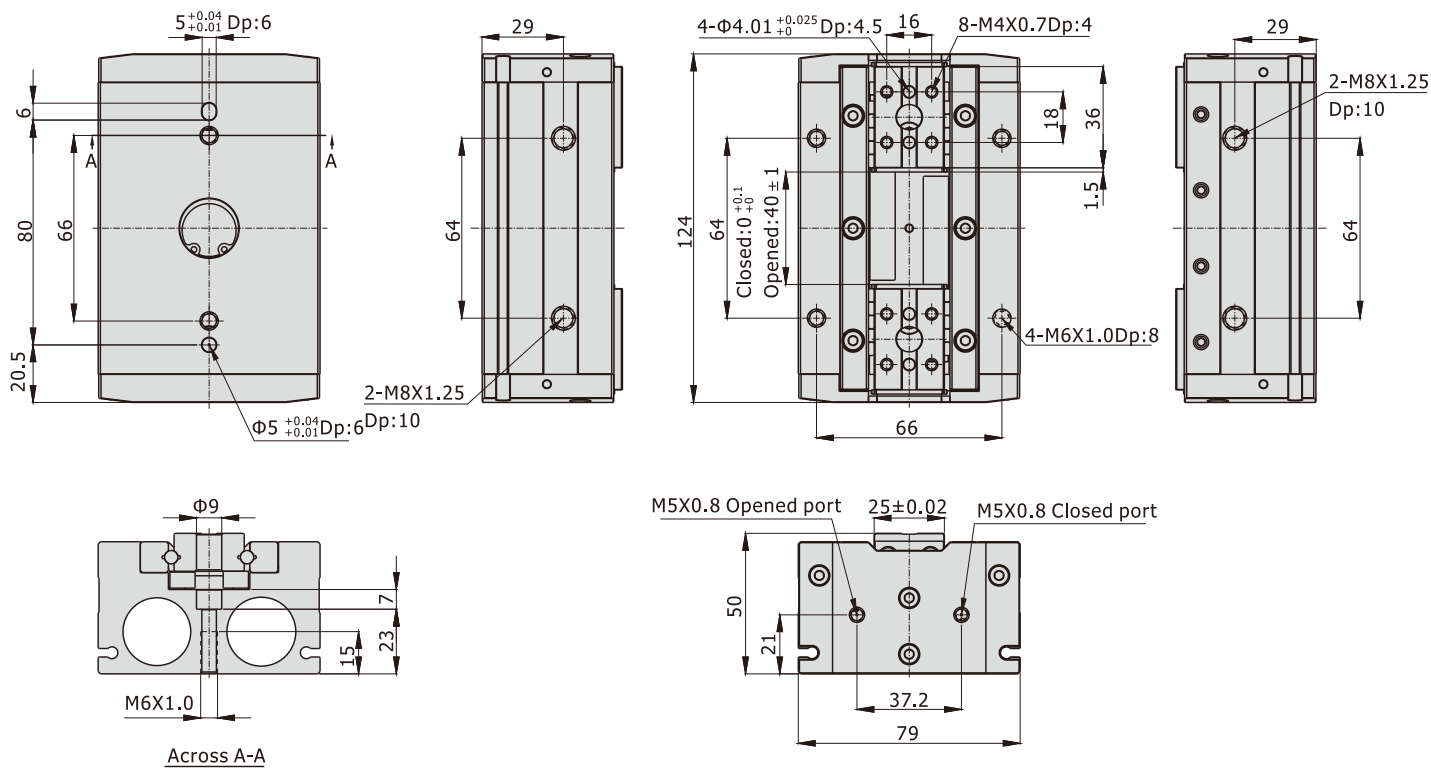

HFD25X80

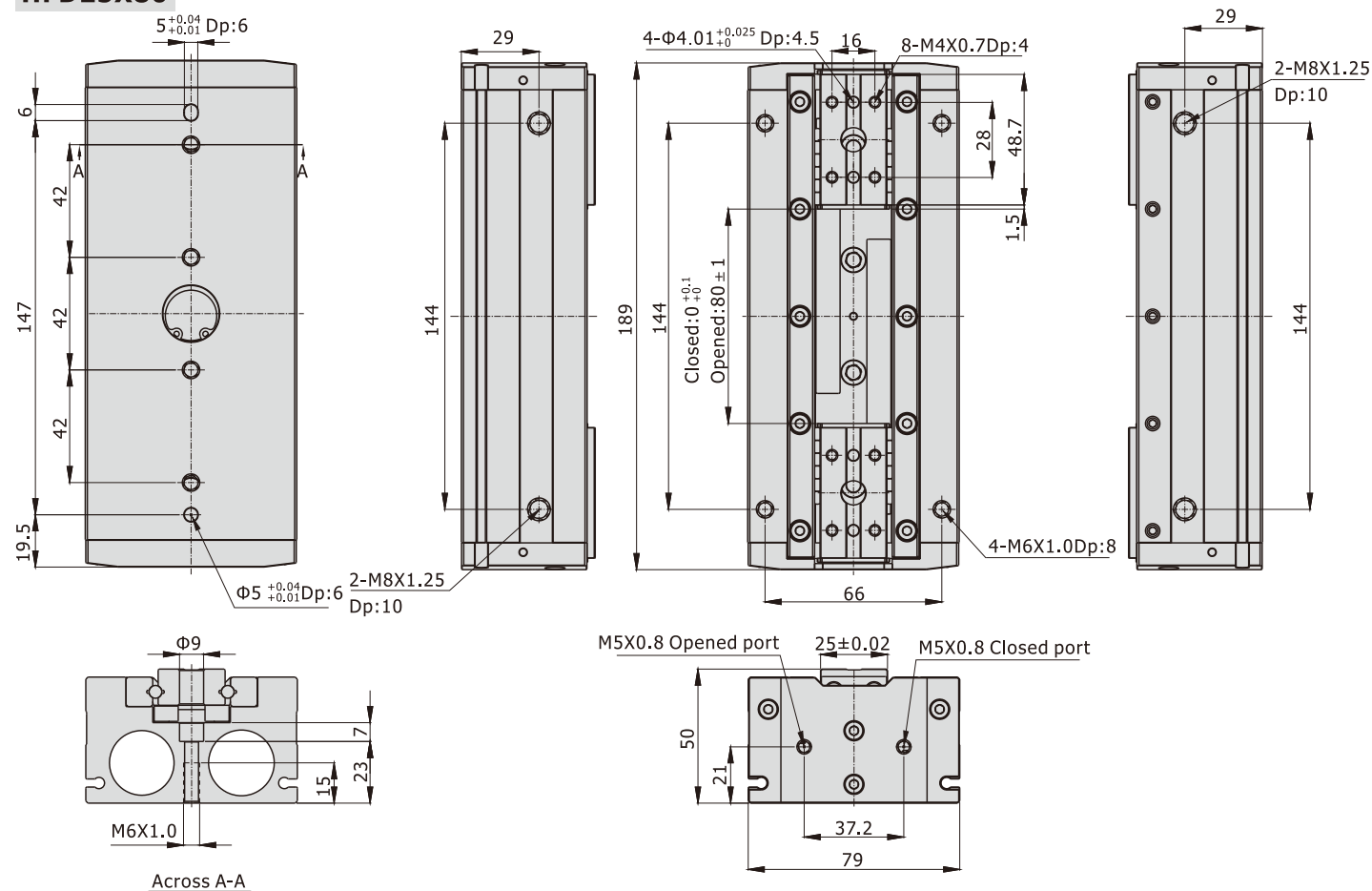

How to select product

Please select pneumatic finger according to the following steps:

① The selection of the effective gripping force

② the confirmation of the gripping point

③ the confirmation of the external force put on the gripping jaw

1. The selection of the gripping force

The gripping work-pieces shown below, on the impact condition of ordinary handling state, taking safety coefficient $a=4$, have a gripping force that is more than 10-20 times of the mass of the gripped objects.

	The work-pieces as shown in the left :		$\mu = 0.2$	$\mu = 0.1$
	n: Number of gripping F: Gripping force (N) μ : friction coefficient between fittings and work-pieces. m: mass of work-pieces g: acceleration of gravity ($=9.8m/s^2$)	The condition that the work-pieces won't drop is: $n \times \mu F > mg$ so: $F > \frac{mg}{n \times \mu}$ Safety coefficient is a, so F is: $F = \frac{mg}{n \times \mu} \times a$	$F = \frac{mg}{2 \times 0.2} \times 4 = 10 \times mg$	$F = \frac{mg}{2 \times 0.1} \times 4 = 20 \times mg$
			10 times of the mass of the gripped objects	20 times of the mass of the gripped objects

Note) If the friction coefficient $\mu > 0.2$, for safety, please also select clamping force according to the principle of 10~20 times of the mass of the clamped objects. As for large acceleration and shock, it requires for greater safety coefficient.

1.1) The actual gripping force must be within the effective gripping forces of different pneumatic fingers specifications shown in the below chart.

Closed gripping force

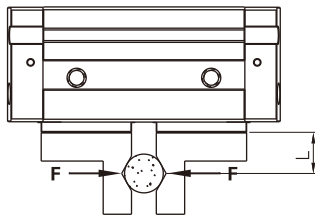

Opened gripping force

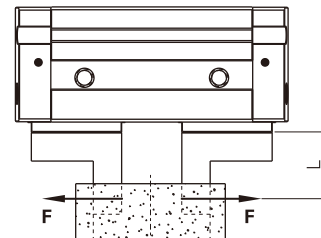

HFD8

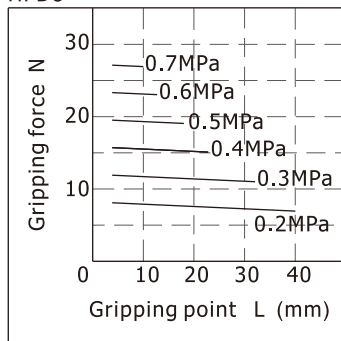

HFD12

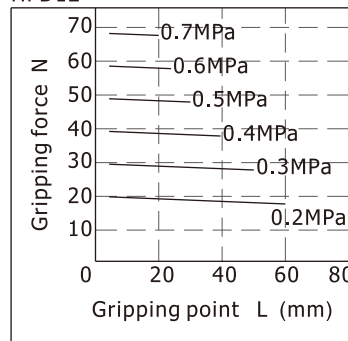

HFD16

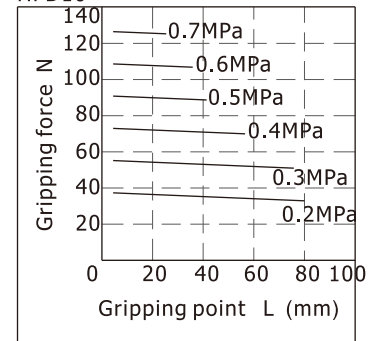

HFD20

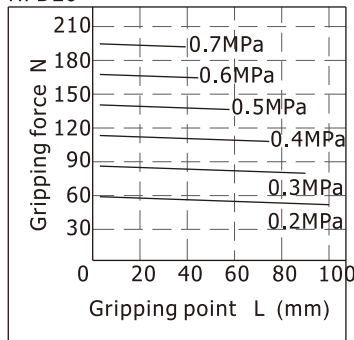

HFD25

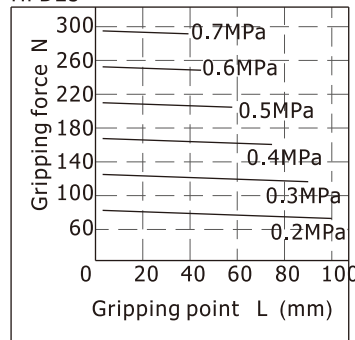

Compact air gripper

HFD Series

Bore size: $\Phi 8$, $\Phi 12$, $\Phi 16$, $\Phi 20$, $\Phi 25$

2. The selection of the gripping point

2.1) Please select the gripping point within the limited field shown below.

Over the limits, gripping jaws would be subjected to excessive torque loads, and lead to short life of the air gripper.

L and H have proper sizes

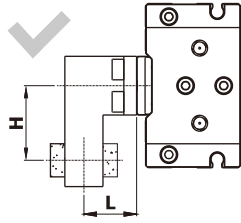

L is too long

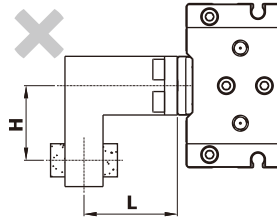

H is too long

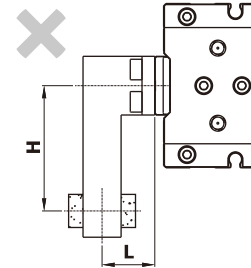

The range of the closed gripping points

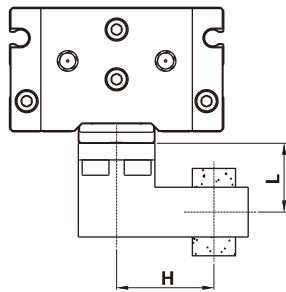

The range of the Opened clamping point

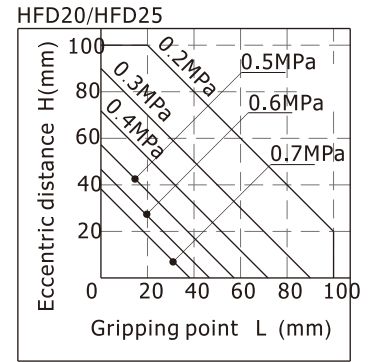
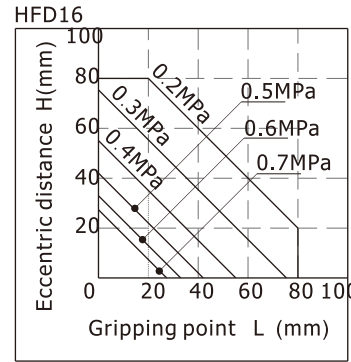
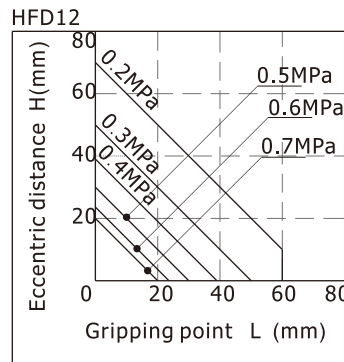
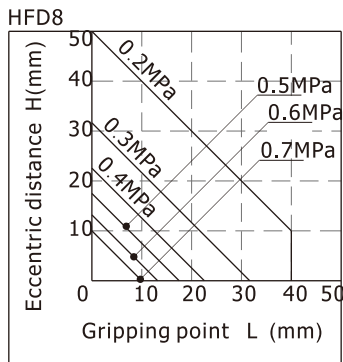
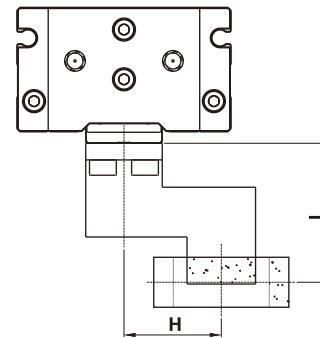

2.2) In the allowable range of gripping point, it is better to design for short and light fittings. If the fittings are long and heavy, the inertia force when the finger is open and close will become larger, and the performance of gripping jaw will be degraded, at the same time it will affect the life.

3. The confirmation of the external force put on the gripping jaw.

Bore size	The allowed vertical loads Fv(N)	Max. permissible torque(Nm)			The calculation of allowable forces when moment loads work	Examples of calculation
		Mp	My	Mr		
8	58	0.26	0.26	0.64	Allowable load(N) $M(\text{Maximum permissible moment})(\text{N.m}) = \frac{L \times 10^{-3}}{\text{Unit conversion constant}}$	In the guide rail of HFD12, the external force of the pitching moment static loads put on the point of L=30mm is f=10 N, $\text{Allowable load } F = \frac{0.68}{30 \times 10^{-3}} = 22.7(\text{N})$ Actual load f=10(N) < 22.7(N) To meet the using requirements
12	98	0.68	0.68	1.68		
16	176	1.4	1.4	3.36		
20	294	2	2	4.8		
25	294	2	2	4.8		

[Note]
The loads and torque values of said are all static values.
L=Distance to load point(mm).

Installation and application

1. Due to the abrupt changes, the circuit pressure is low, which will lead to the decrease of the gripping force and falling of the work-pieces. In order to avoid the harm to the human body and damage to the equipment, anti-dropping device must be equipped.
2. Don't use the air gripper under strong external force and impact force.
3. When install and fix the air gripper, avoid falling down, collision and damage.
4. When fixing the gripping jaw parts, don't twist the gripping jaw.
5. There are several kinds of installation method, and the locking torque of fastening screw must be within the prescribed torque range shown in the below chart. If the locking torque is too large, it will cause the dysfunctional. If the locking torque is too small, it will cause the position deviation and fall.

Tail installation type

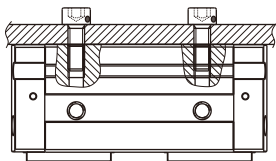

Bore size	The bolts type	Max. locking moment (N.m)	Max. screwed depth (mm)
8	M3×0.5	0.95	6
12	M4×0.7	2.2	8
16	M5×0.8	4.5	10
20	M6×1.0	7.8	15
25	M6×1.0	7.8	15

Side installation type

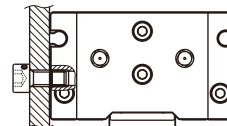

Bore size	The bolts type	Max. locking moment (N.m)	Max. screwed depth (mm)
8	M3×0.5	0.63	4
12	M4×0.7	1.5	5
16	M5×0.8	3	5.5
20	M6×1.0	5.2	8
25	M8×1.25	12	10

Bottom installation type

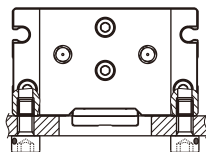

Bore size	The bolts type	Max. locking moment (N.m)	Max. screwed depth (mm)
8	M3×0.5	0.63	4
12	M4×0.7	1.5	5
16	M5×0.8	3	5.5
20	M6×1.0	5.2	6
25	M6×1.0	5.2	8

Front installation type

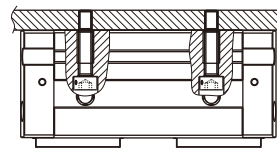

Bore size	The bolts type	Max. locking moment (N.m)
8	M2.5×0.45	0.36
12	M3×0.5	0.63
16	M4×0.7	1.5
20	M5×0.8	5
25	M5×0.8	5

7. The installation method of the gripping jaw fittings

When install the gripping jaw fittings, you have to pay particular attention that you can only hold the gripping jaw by using spanner, and then lock the screws with allen wrench. Never clamp the body directly and then lock the screws, otherwise the parts will be easily damaged.

Bore size	The bolts type	Max. locking moment (N.m)
8	M2.5×0.45	0.36
12	M3×0.5	0.63
16	M4×0.7	1.5
20	M4×0.7	1.5
25	M4×0.7	1.5

