



Series Stepper 12



Proportional Flow Control Valve

The Spartan Scientific Stepper 12 Steppervalue is a self-contained Media Separated Electronic Proportional Flow Control Valve designed for highly accurate electronically controlled variable flow control of inert fluids and gases. Using analog or digital signal inputs to produce a linear variable flow output, this combination of a stepper motor, valve body with controller circuit has more than 1,500 positions through its valve stroke which can be dialed down to the step, creating reliable and repeatable flow rates from 0 to 30 GPM (water) @ 150 PSI. The valve features a built-in electronic control that accommodates either open or closed loop control by use of electronic signal input of either 4 to 20 mA, 0 to 10 Volt DC. Valve standard operating voltages are 12 or 24 VDC. The Stepper 12 has a separating diaphragm that maintains dry mechanical movement and is designed for long life and high flow. The diaphragm is designed with a specialized convolution and elliptical flow tip producing a linear flow versus valve stroke position. The Stepper 12 valve body is available in 1/4", 3/8" or 1/2" port sizes with a maximum flow orifice of 12.5mm. Featuring multi orientation mounting and the quick connect M12 connector mates to the valve for a sure environmentally resistant enclosure to NEMA 4/IP 65. This energy saving valve uses voltage to move into position and needs only 60mA when position is found and maintains a steady state. For fast troubleshooting, the on-board indicator LED (RGB) light ring displays status of the device.

Dimensional Data

ALL DIMENSIONS ARE IN INCHES UNLESS OTHERWISE NOTED

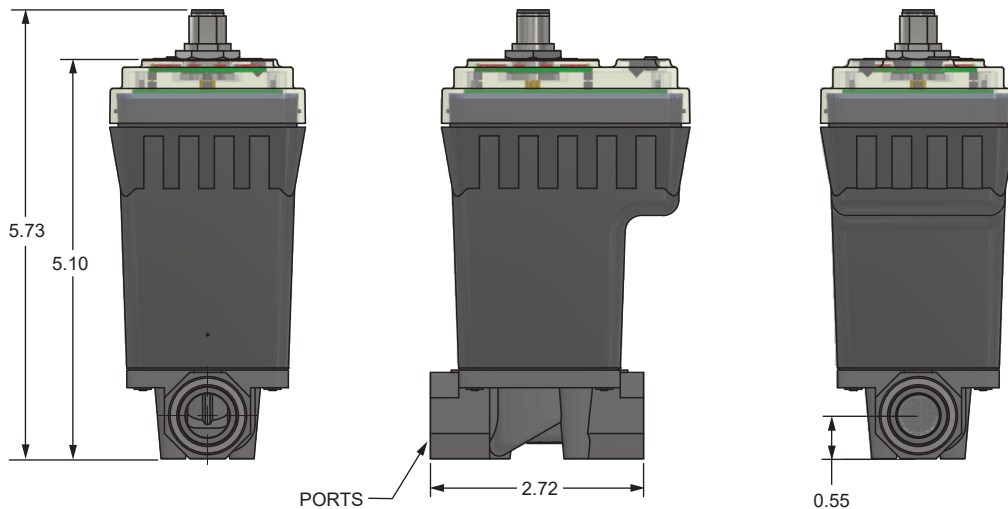
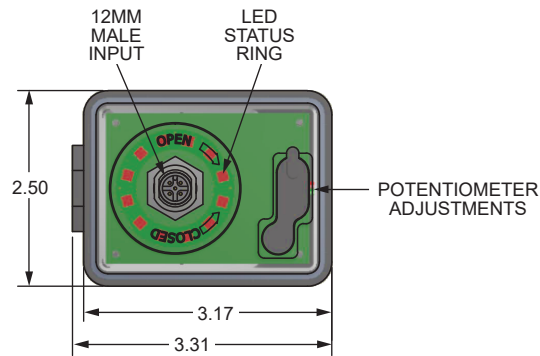

FEATURES

- Highly accurate electronic variable flow control of inert fluids and gases
- Combination stepper motor, valve body with controller circuit accommodates more than 1,500 valve stroke positions
- Built-in electronic control accommodates open or closed loop with signal input

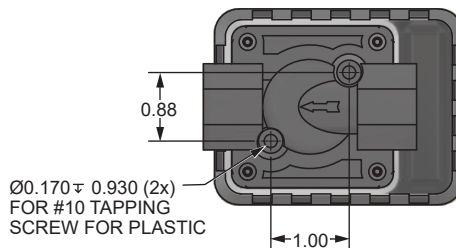

PROPORTIONAL FLOW



Series Stepper 12

Proportional Flow Control Valve

Technical Data

Function: 2-Way, 2-Position; Media separated, Proportional flow, Stepped controlled valve, Open or Closed loop

Port Size: 1/4", 3/8" and 1/2" NPT

Orifice Sizes / Flow Factor: 1/2" / 2.45 Cv

Pressure Range: 0 to 150 psi (In dead head situations, max operating pressure is 80 psi.)

Flow Range: 0 to 30 gpm

Temp. Range: Fluid Max.: +60°C Ambient +10° to +50°C

Media: All fluids and gases compatible with wetted materials

Environment Protection: IP65 (IEC 144), NEMA 4 Dust-tight and water resistant

Mounting: On pipe or (2x) 0.170 blind holes for #10 tapping screw

Wetted Materials: Elastomers: FKM, NBR, EPDM (Available in FDA compatible and NSF versions, Consult Factory)
Valve Body: Glass-Filled Nylon Zytel77G33L
Flow Control Element/Seat Coupling: 316 Stainless Steel
Port Screen: 300 Series Stainless Steel

Electronics: Control Signal: 0 to 10 volts or 4 to 20 mA
Feedback Control: 0 to 10 volts or 4 to 20 mA
Connection: M12 Round Connector, Code A

Packaged Weight: 1.7 lbs.

Function

Analog Inputs - The two separate analog inputs are **Control Input** and a **Feedback Input**. These inputs can operate as voltage inputs with an input range of 0 to 10 VDC or operate as a current input with an input range of 4 to 20 mA. Analog inputs are configured at the factory and must be specified at ordering time. See the "How To Order" section for specific ordering information.

| ANALOG INPUTS | INPUT TYPE |
|----------------|---|
| Control Input | Voltage Input: 0 to 10 VDC or Current Input: 4 to 20 mA |
| Feedback Input | Voltage Input: 0 to 10 VDC or Current Input: 4 to 20 mA |

Analog Outputs - The Stepper 12 valve can be controlled by the analog outputs of a PLC by providing either voltage or current signal to operate the device.

Potentiometer Adjustments - Two single turn potentiometers are located under the black rubber cover. **Pot "S"** is for controlling the Speed that stepper opens or closes. **Pot "D"** is for controlling the dither or hysteresis. This pot is used with how the STEP12 operates when the device is in Closed loop mode and is based on the difference between the Control and Feedback inputs.

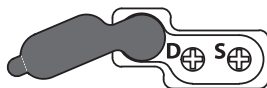

Modes - The device operates in Open Loop or Closed Loop mode based on the input level of the Closed or Open Loop Signal which is pin 5 of the M12 connector.

| SWITCH CONTROL STATE | OPERATION |
|----------------------|-------------------------------|
| 0 VDC | Device is in Open Loop Mode |
| 24 VDC | Device is in Closed Loop Mode |

Average Flow vs Input Voltage - 1/2" NPT Port

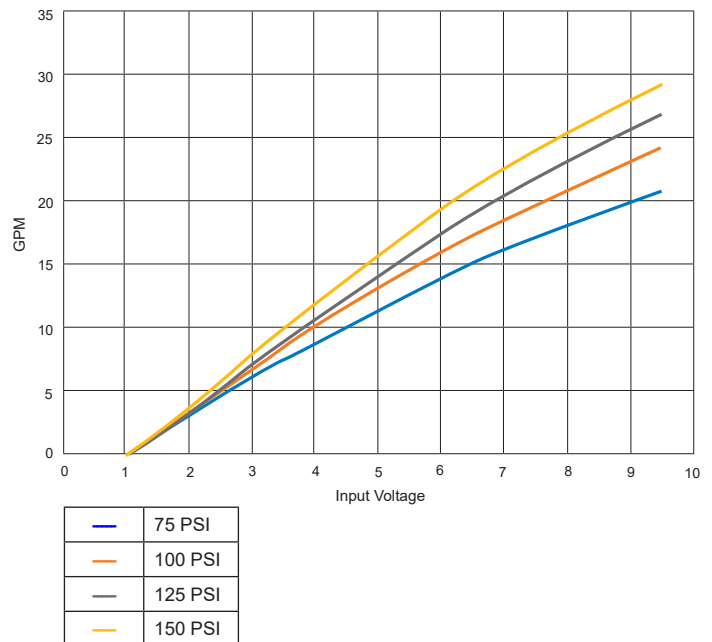

Additional Information -

- Test voltage parameters 0.5 to 9.5 volts DC with step range 0 to 1500.
- Slope and Volumetric Output will vary with pressure input.
- Media used is water at 70°F.

*The data contained in this document is the property of Canfield Industries, Inc., Canfield Connector, Inc. and Spartan Scientific, Inc. and is not to be reproduced or redistributed without the expressed written consent of Canfield Industries, Inc.



Series Stepper 12

Proportional Flow
Control Valve

Hook-up

Pin Configuration

The male M12 connector powers the device providing the Control and Feedback Inputs.



12mm Male Input
A-Coding

| PIN | FUNCTION |
|-----|----------------------------|
| 1 | Input Voltage |
| 2 | Feedback Signal |
| 3 | Ground |
| 4 | Control Signal |
| 5 | Closed or Open Loop Signal |



12mm Female Locking
Connector

| PIN | COLOR |
|-----|-------|
| 1 | Brown |
| 2 | White |
| 3 | Blue |
| 4 | Black |
| 5 | Gray |

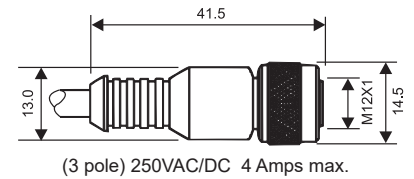

How To Order

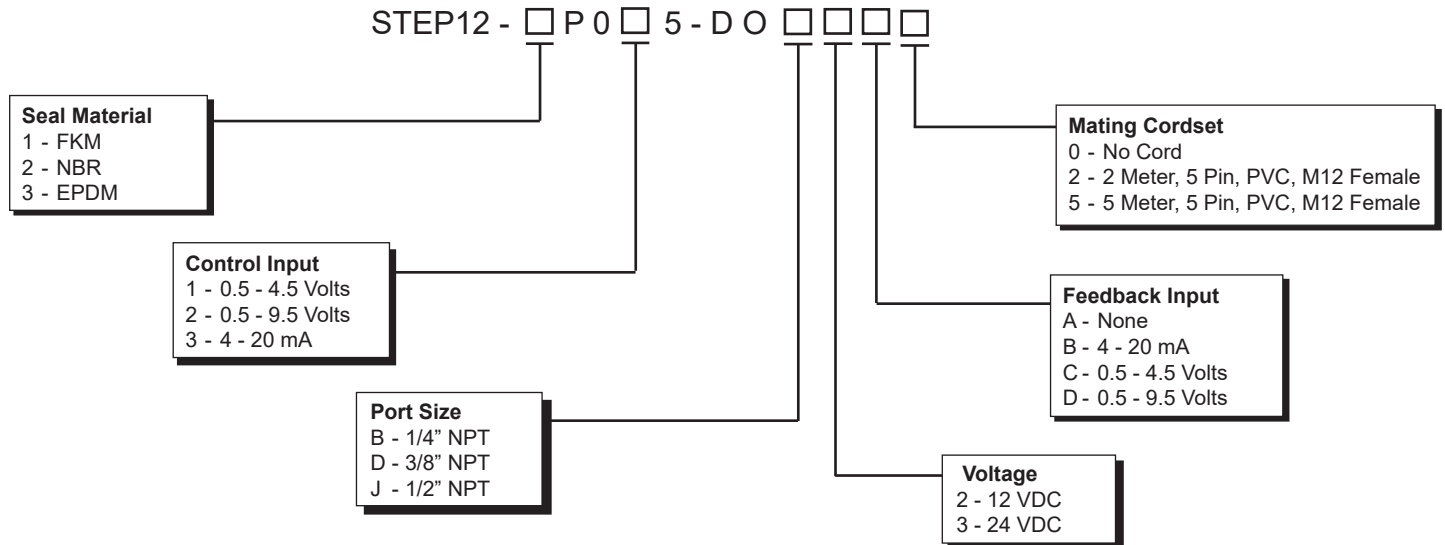

Order Example: STEP12-1P015-DOB2B2
FKM, 0.5 - 4.5 Volts, Glass Filled Nylon,
1/4" NPT, 12 VDC 4 - 20 mA, 2 Meter Cordset